

LEXRON[®] 25.6V 100Ah LiFePO4 Batteries



LEXRON Provides Safe and Efficient LFP Battery Solutions.

LXR series adopt best value LiFePO4 cells, with the BMS system independently designed by LEXRON. series and parallel use, is energy storage, marine and other fields. IP65 protection, support an ideal choice for outdoor, small

Features

- Bluetooth access to show functions like
- Lithium iron Phosphate Battery(LiFePO4)
- Eco-friendly
- Special protection plate
- Multiple safety protection
- Intelligent balancing function
- 20 Years Designed service life

Mechanical Specifications

Case Material	ABS
Cell Type-Chemistry	Prismatic LiFePO4
Terminal Type	M8
IP Grade	IP65

BMS Characteristics

Recommended Charge Current	100A
Maximum Charge Current	100A
Maximum Continuous Discharge Current	100A
Recommended Charge Voltage	27.8~28.6V
Max Charge Voltage	29.2V
Overcharge Protection Voltage	29.4~29.8V
Charge Mode	CC/CV
Discharge Cut-off Voltage	21.6V

Basic Performance

Nominal Voltage	25.6V
Nominal Capacity	100Ah
Standard Discharge Time	100A@60min
Capacity	2.56KWh
IR	$\leq 15m\Omega$
Self Discharge	$\leq 2\%/Month$
Cells	Square 100Ah
Cycle Life	4000 times(80%DOD)
Size (mm)	522*238*223
Weight (kg)	19.5

Charge Performance

Rated Charge Current	100A
Maximum Charge Current	100A
Rated Charge Voltage	27.8~28.6V
Charge Cut-off Voltage	$> 29.2V(0.5\sim 1.5S)$
Reconnect Voltage	$< 28.8V$
Balancing Voltage	$< 28V$
System Series	≤ 2

Discharge Performance

Rated Discharge Current	100A
Pulse Current($\leq 5S$)	200A
Rated Discharge Cut-off Voltage	21.6V
Minimum Discharge Cut-off Voltage	$> 20.5V$
Reconnect Voltage	$> 20.8V$
Short Circuit Protection	200~600 μs
Short Circuit Current	Approx. 1000A

Temperature Performance

Discharge Temperature	-20~65°C
Charge Temperature	-5~60°C
Storage Temperature	-10~40°C
High Temperature Cut-off	65°C
Reconnect Temperature	45°C

Compliance

Certifications	CE/UN38.3/UL1973/IEC62619
Transport Appraisal	UN3480,CLASS 9

Size

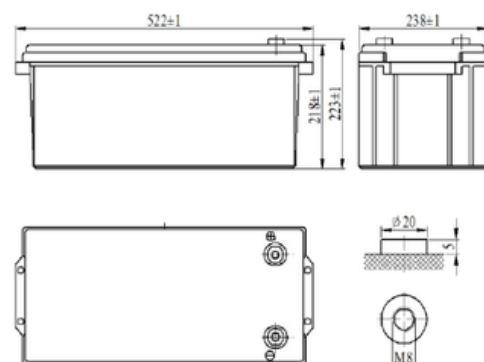

Characteristics Curve

Discharge Performance at 25°C

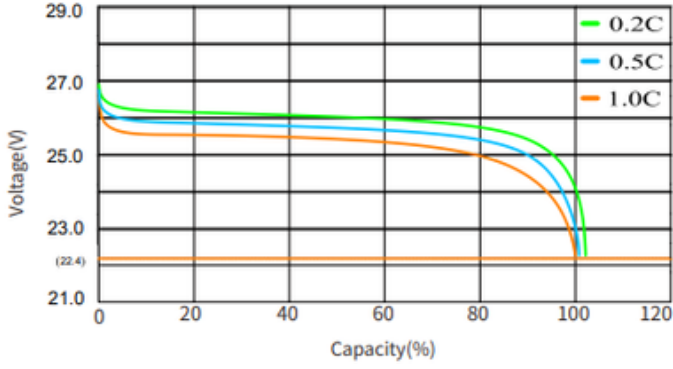

Charge and Discharge at 25°C, 0.5C

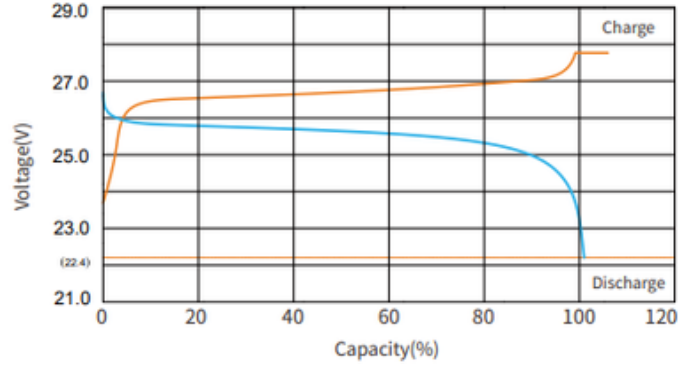

Temperature Effects on Capacity at 0.5C

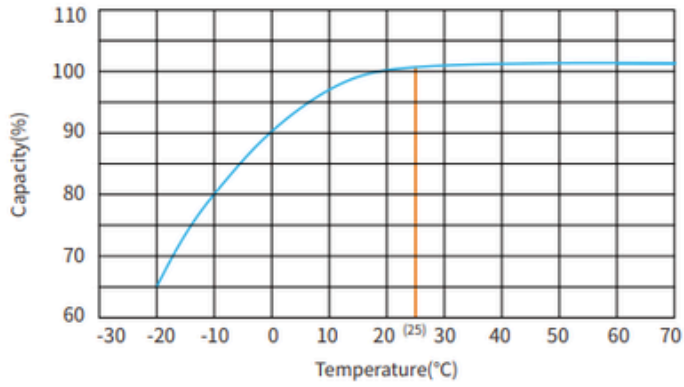

Cycle Life with DOD at 25°C
1C Discharge and 1C Charge

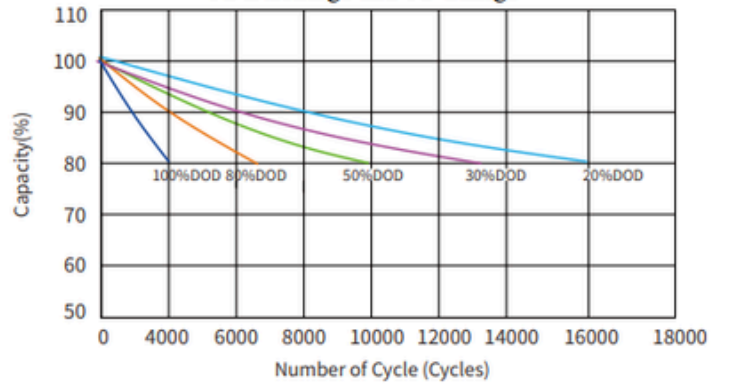

Cautions

1. Do NOT short circuit, crush or disassemble.
2. Do NOT heat or incinerate.
3. Do NOT immerse in any liquid.
4. Store at 50% capacity. Recharge every 3 months. The storage area should be clean, cool, dry and ventilated.
5. Disconnect charging source prior to connecting or disconnecting battery terminals.
6. Do not dispose of batteries in a fire as they can explode.
7. Do not open, alter, or mutilate batteries.
8. Do not mix different types and brands of lithium-ion batteries.
9. Do not dispose in trash, follow local regulations and manufacturer's instruction.
10. See installation instructions before connecting to the supply.
11. The battery cabinet receives power from more than one source. Disconnection of all DC sources is required to De-energize this unit before installing or servicing. Wait 5 minutes before opening the unit.
12. Do not install on or over combustible surfaces.